

# *Enviro-Met Ltd*

Rubicon Centre, Broad Ground Road  
Redditch, Worcs. B98 8YP  
Tel/Fax. 01527 516579

## Emissions to Air from Atritor Ltd, Coventry

**Report No EM3170**

**19 September 2002**



Registration No. GB4683

ENVIRO-MET LTD. Registered in England & Wales Company No. 2716910  
Registered Office: Redditch B98 8YP. Directors, Mr T N Blackman, Mrs C A Hanks



EM3170  
19 September 2002

**Emissions to Air**  
**from**  
**Atritor Ltd, Coventry**

**1. Introduction**

The above site was visited on the 18<sup>th</sup> September 2002 in order to carry out tests to quantify the emissions to air from the foundry. These tests are required as a condition of authorisation of the process and the results should be forwarded to the local authority within eight weeks of completion of testing.

Testing was carried out by C A Hanks BSc (Hons) MIOSH.

**2. Methods of Test**

The particulate tests were carried out in accordance with BS3405:1983, as far as conditions allowed, using a BSC design sampling probe.

For the test on the shotblast, the particulates were collected onto glass fibre filter papers that have a nominal weight of 25mg and the mass of particulate collected was determined gravimetrically after conditioning overnight.

The particulates from the main foundry extraction were collected onto glass wool depth filters that has a nominal container weight of 25g, the mass collected was determined gravimetrically after drying at 140°C. The use of relatively heavy depth filters means that at low emission concentrations it is unlikely that sufficient mass of particulates will be collected to satisfy the requirements of BS3405. (minimum of 0.3% of the container mass). However, the resolution of the balance is greater than that required of the standard and reproducibility of the weighings is shown to be good. The use of depth filters will have no effect on the accuracy of the test. Depth filters are the preferred option when sampling ducts where the discharge is likely to comprise granular particulates, often these do not adhere to filter papers and may be lost during handling and transport which can result in an underestimation of emission levels.

Airflow and velocity measurements in the ducts were determined using an ellipsoidal pitot-static tube and electronic manometer. Temperature measurements were made using a K-type thermocouple and electronic thermometer. The manometer, thermometer and balance all have calibrations traceable to NPL standards.

All results are reported under standard conditions of 0°C, 101.3 kPa, uncorrected for water vapour. A full sampling protocol is included in the Appendix.

### 3. Results

Full results of the particulate emission tests and conditions in the ducts are given in the tables at the end of this report. A summary of the main findings is produced below.

Duct	Run No.	Time min	Vol. lt.	Wt collected mg	Concentration mg/m <sup>3</sup>
Main foundry extraction	1	32	780	6.4	8.2
	2	30	728	17.2	23.6
Shotblast	1	20	632	0.93	1.5
	2	20	629	0.61	1.0

### 4. Comments

The test on the shotblast did not comply with BS3405 due to unsuitable flow conditions at the sample plane. Sampling was carried out at a single point where flow was at a maximum.

The shotblast discharge has been altered and no longer discharges to atmosphere, hence no emission limit should apply. The results of the test show that the filter is working satisfactorily and given the short operational period of the shotblast, typically less than one hour a day, there is no problem with discharging the air back into the workplace.

The sampling conditions of the test on the main foundry extraction fully met the requirements of BS3405 except the variation in the results of the two sample runs was greater than the 1.5:1 permitted in the standard. However, this is a reflection of the different operational conditions during the two runs and does not imply any reduction in the accuracy of the test.

The results show that emission during knockout periods (20 minutes, up to three times a day), were around half the emission limit. Emissions at other times were shown to be substantially less at around 8mg/m<sup>3</sup>.

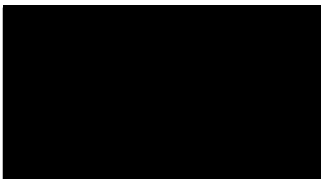

C A Hanks, BSc (Hons), MIOSH

**Particulate emission test to BS3405:1983**

**Atritor Ltd**  
**Main foundry extraction**  
**Date: 18/9/02**

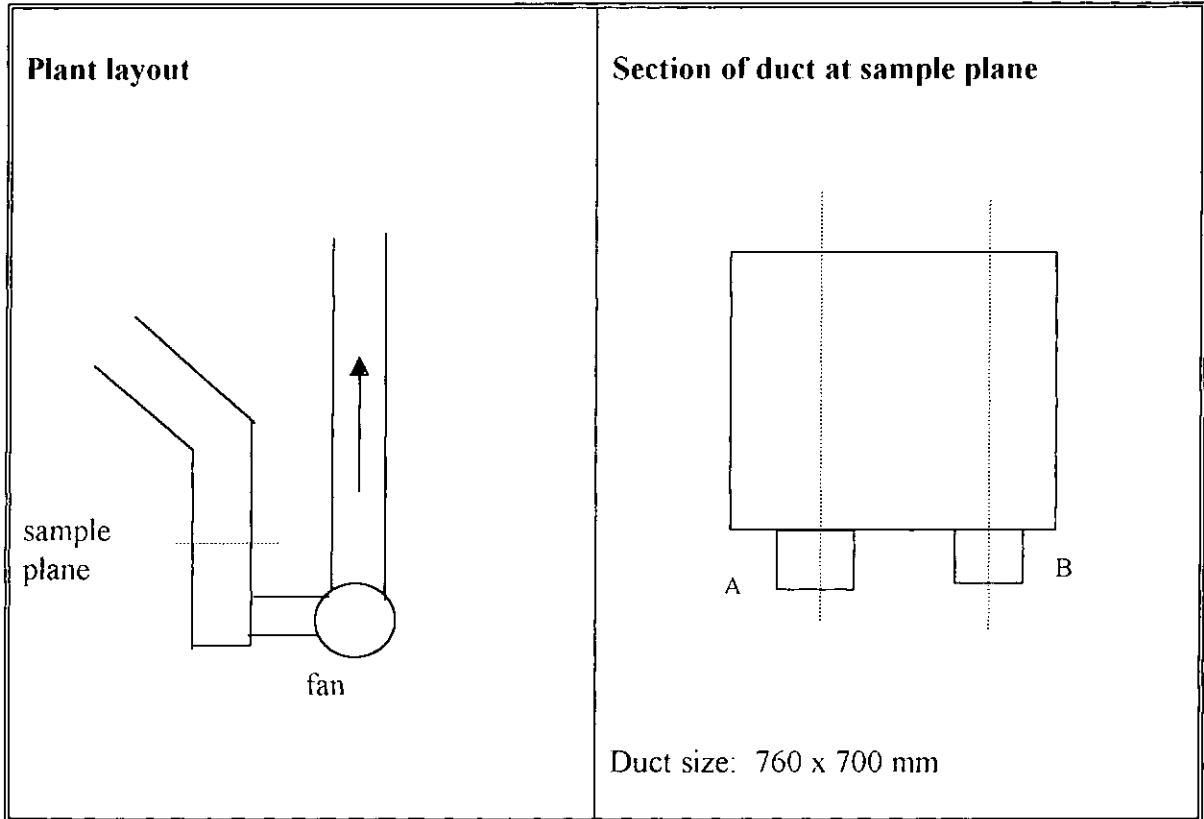

**Process/test conditions**

Arrestment type	wet arrestor
Particulate type	ferrous foundry particulate
Appearance of plume	visible emission during knockout only
<p>Sample ports located in downcomer from wet arrestor, 1m after 45° bend and 750mm before entry into fan.</p> <p>Extraction from sand plant, knockout grid and furnace canopy hood.</p> <p>Run 1, sand plant in operation and furnace being emptied.</p> <p>Run 2, knockout grid in use for 20mins, furnace being re-charged.</p>	

**Conformance**

The test complied with BS3405 except that the variation between the two sample runs was greater than permitted in the standard.

**Main extraction**

Duct size	0.760 m x 0.700 m
Duct temperature	18 °C
Atmospheric pressure	101.7 kPa
Static pressure in duct	-8.26 "wg -2057 Pa
Mean velocity in duct	14.25 m/s
Gas flow rate	25188 Nm <sup>3</sup> /hr

Preliminary Survey

Pitot-static pressures ("wg)

Position (xD)	0.125	0.25	0.375	0.50	0.625	0.75	0.875
Traverse A	0.34	0.35	0.35	0.34	0.36	0.36	0.35
Traverse B	0.53	0.63	0.68	0.72	0.69	0.65	0.63

Ratio of highest to lowest pitot-static reading: (Max 9:1)                      2.12 :1

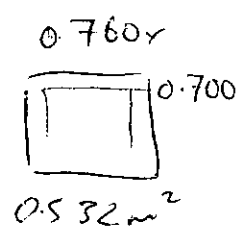

Sampling details

Nozzle size: 1/4"    Number of sample points: 4

Position	0.25A	0.75A	0.25B	0.75B
<b>Run 1</b>				
Velocity pressure "wg	0.35	0.36	0.63	0.65
Flow rate l/min	23	23	30	31
Pump temp °C	30	32	35	36
<b>Run 2</b>				
Velocity pressure "wg	0.35	0.37	0.62	0.67
Flow rate l/min	23	23	30	31
Pump temp °C	33	34	38	38
velocity pressure end	0.35	0.36	0.63	0.67

114.02

18°C + 29.4°C  
→ no variation

Pump correction factor:            Run 1: 0.911                      Run 2: 0.908

Variation in sum of velocity pressures during test: (Max 10%)

Run 1    1.01 %                      Run 2    0.00 %

Results

	Run 1	Run 2
Filter No.	D1	D9
Duration. min	32	30
Condensate. mls	0	0
Volume sampled.lt	780	728
Weight collected. mg	6.4	17.2
Concentration mg/m <sup>3</sup>	8.20	23.62

Ratio of final emission concentrations: (Max 1.5:1)                      2.88 :1

**Particulate emission test to BS3405:1983**

**Atritor Ltd**  
**Shotblast**  
**Date: 18/9/02**

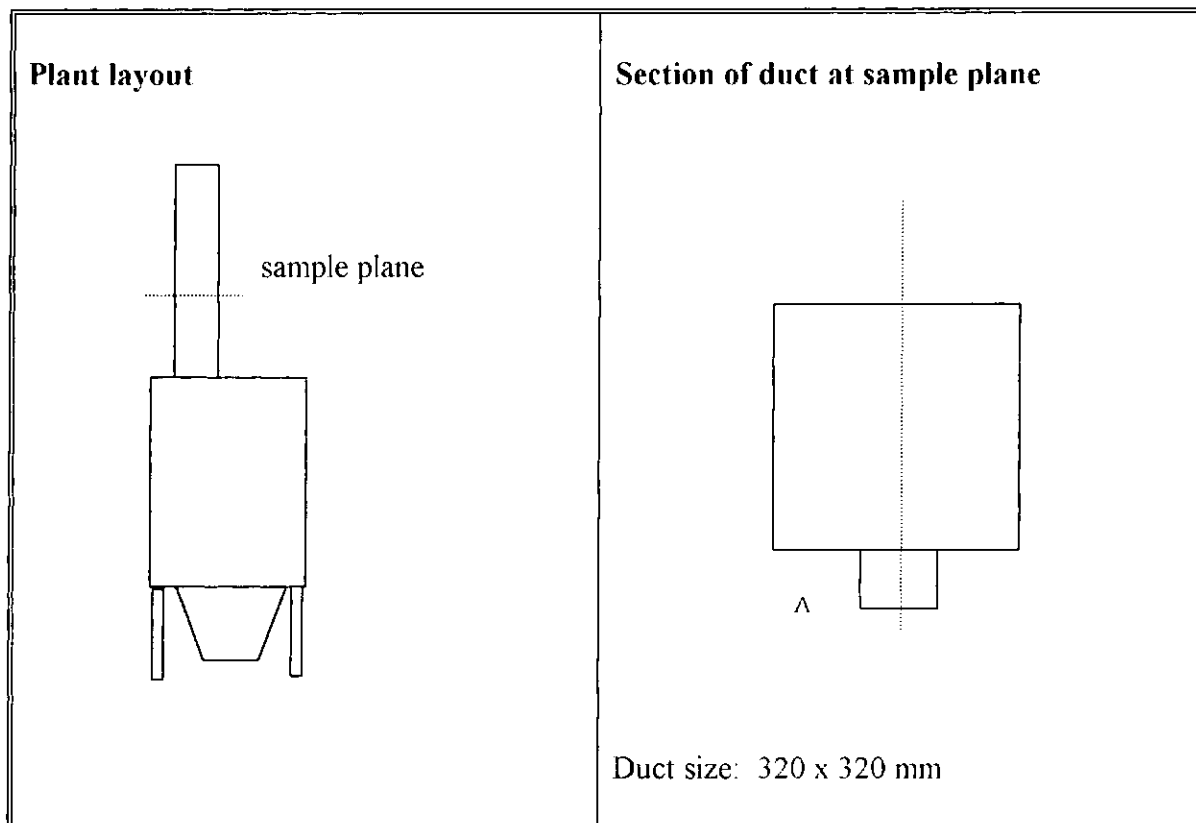

**Process/test conditions**

Arrestment type	bag filter
Particulate type	grinding dust
Appearance of plume	none
<p>Sample port located in vertical discharge duct, 400 mm above cabinet.          Cabinet now discharges internally back into the workplace.</p> <p>One load of castings cleaned during each sample run.</p>	

**Conformance**

Test did not comply with BS3405 due to poor flow conditions at the sample plane.

## Shotblast

Duct size	0.320 m x 0.320 m
Duct temperature	26 °C
Atmospheric pressure	101.7 kPa
Static pressure in duct	0.18 "wg 44.82 Pa
Mean velocity in duct	2.47 m/s
Gas flow rate	836 Nm <sup>3</sup> /hr

### Preliminary Survey

Pitot-static pressures ("wg)

Position (xD)	0.125	0.25	0.375	0.50	0.625	0.75	0.875
Traverse A	0.00	0.00	0.00	0.00	0.04	0.06	0.16

Ratio of highest to lowest pitot-static reading: (Max 9:1) >9 :1

### Sampling details

Nozzle size: 3/8" Number of sample points: 1

Position		0.875		
<b>Run 1</b>				
Velocity pressure "wg		0.16		
Flow rate l/min		34.5		
Pump temp °C	26	30	32	33
<b>Run 2</b>				
Velocity pressure "wg		0.16		
Flow rate l/min		34.5		
Pump temp °C	30	32	34	36
velocity pressure end		0.16		

Pump correction factor: Run 1: 0.916 Run 2: 0.912

Variation in sum of velocity pressures during test: (Max 10%)

Run 1 0.00 % Run 2 0.00 %

### Results

	Run 1	Run 2
Filter No.	E676	E677
Duration. min	20	20
Condensate. mls	0	0
Volume sampled.lt	632	629
Weight collected. mg	0.93	0.61
Concentration mg/m <sup>3</sup>	1.47	0.97

Ratio of final emission concentrations: (Max 1.5:1) 1.52 :1

0.00093

# APPENDIX



## Enviro-Met Ltd

### Isokinetic Sampling To BS3405:1983

Particulate sampling is carried out using either the Enviro-Met isokinetic sampler, based on a BSC design or a Zambelli ZB2 sampler, the design of which complies with BS 3405. The equipment consists of an in-stack filter, water-cooled condenser (for hot applications), sample pump and flow measurement device. Pressure, air velocity and flow rates are measured using an ellipsoidal pitot-static tube and electronic manometer. Temperature measurements are made using a k-type thermocouple and electronic thermometer.

The tests are carried out adopting the following protocol:

#### **A Preparation**

- 1 Verify sampling ports are fitted and in accordance with the requirements of BS3405. Ensure there is safe access and platform at the sampling position and that power will be available locally. Check whether there are any potential hazard such as dangerous gases.
- 2 Establish the likely levels of emissions and whether there may be cyclical variations in the process. Determine sampling times and duration accordingly. Minimum sample times of 60 minutes are normally used.
- 3 Check isokinetic sampler and measuring equipment is working correctly.
- 4 Pack depth filters with a tightly packed layer of ultrafine glass fibre followed by a loosely packed layer of fine glass fibre. Dry depth filters in an oven at 120°C overnight and cool in a desiccator. Weigh to a constant weight using a four figure balance weighing to 0.1mg.
- 5 Leave GFA filter papers to equilibrate for 24hrs in the weighing room before weighing to a constant weight on a five figure balance to 0.01mg. Weigh two blanks per batch to compensate for any humidity or temperature changes.

#### **B On site**

##### Preliminary

- 1 Ensure access and sample position is safe. Carry out a risk assessment prior to commencement of sampling. If any risk is considered "high" do not commence sampling until measures to reduce the risk have been taken.
- 2 Agree on notification and emergency evacuation procedures.
- 3 Determine that the plant is operating under normal conditions. Arrange for notification in the event of any stoppages or abnormal conditions.

##### Sampling Procedure

- 1 Carry out preliminary survey at ten points across both traverses of the duct for pitot-static pressure. Velocity pressure across the duct should not vary by more than a factor of 9:1
- 2 Note the extent of any swirl, the direction of flow should not be more than 20° to axis of the duct.
- 3 Measure the duct static pressure and record any variation in temperature across the duct. Record the atmospheric pressure.

- 4 Calculate ratio of highest to lowest pitot static measurements and assess whether sampling can be carried out in accordance with BS3405 and if so whether 4 or 8 point sampling is necessary.
- 5 Select a suitable nozzle and calculate the flow rate to achieve isokinetic sampling. For cumulative sampling the product of sample time and nozzle area must remain constant.
- 6 Assemble sampling equipment train and check for leaks.
- 7 Load a clean filter into the sample head and locate the sample probe at the first sample point with the nozzle facing upstream, start the pump and stopwatch simultaneously. Adjust the flowrate so the calculated sample rate is shown on the rotameter.
- 8 Record the temperature of the exhaust gas during the test.
- 9 At the end of the required sample time move the sample head to the next position and adjust the flow rate to maintain isokinetic sampling conditions.
- 10 When all points have been sampled transfer the sample filter to a clean dry transport container. In order to remove any particulate adhering to the nozzle, brush through the nozzle and sample head surfaces into the transport container.
- 11 Re-measure the pitot static pressures at the points sampled. Variation in the sum of the measurements should not exceed 10%.

#### **C Processing**

- 1 Dry depth filters overnight at 120°C, re weigh after cooling in a desiccator.
- 2 Filter papers are dried and weighed following the same procedure as during the preparation stage. Any difference in the weight of the blank is taken into account when determining the mass collected

#### **D Metal analysis**

- 1 Where determination of emissions concentrations of specific metals, such as lead copper etc. are required, the filters used for the particulate test will be sent to a NAMAS accredited laboratory for analysis.
- 2 The analysis method is chosen by the laboratory as being the one most suitable for the metal and the media it is presented on.
- 3 The most popular method is an in-house method based on NIOSH 7300, acid dissolution followed by determination by inductively coupled plasma (ICP) analysis.

#### **E Reporting**

The report will include the following:

Description of plant and process operation

Activity level during the period of test

Method of sampling and standard to which sampling is carried out.

Physical conditions in duct.

Gas temperature

Velocity profiles

Mean velocity

Mean volume flow

Results of the emission test

Discussion and interpretation of the results, including details of compliance with any stated emission limit, comments on the effectiveness of abatement equipment along with recommendations where appropriate.

Statement of conformity and identification of any deviation from the stated standard.

The flow rates in the duct and the final emission concentration results are calculated using the following equations.

### Mean gas velocity

$$v_{(\text{mean})} = \sqrt{(2/\rho) \cdot \sqrt{h}} \\ = \text{m/s}$$

$\rho$  = density of air  
 $h$  = mean velocity pressure (Pa)

### Mean gas flowrate (Q)

$$Q = v \cdot A \cdot (273/T + 273)(DP/101.3) \\ = \text{Nm}^3/\text{s}$$

$A$  = area of duct ( $\text{m}^2$ )  
 $T$  = duct gas temp ( $^{\circ}\text{C}$ )  
 $DP$  = duct pressure (static pressure + atmospheric pressure)

### Sample volume (at $0^{\circ}\text{C}$ )

$$V = \sum(f\phi)\omega \\ = \text{lt}$$

$f\phi$  = product of flowrate and sample duration at each point  
 $\omega$  = temp. correction factor.

### Concentration of particulates (at $0^{\circ}\text{C}$ )

$$C = m \cdot 1000/V \\ = \text{mg}/\text{m}^3$$

$m$  = mass collected on filter

## **F. Calibration of Continuous Monitors**

Where continuous monitors are installed at the sample points and these are fitted with a data logging facility, then the units may be calibrated using the results of the particulate emission test.

The exact time of the start and finish of each sample run is noted and the data logger can later be interrogated to find the response over that same time period. The actual emission concentration determined from the particulate test can then be compared with the response of the continuous monitor and if there is a difference than the calibration factor of the instrument can be re-calculated and altered as necessary.

Some instruments do not have a simple means of interrogation at a later date, or the calibration mode overwrites, and in these cases the calibration mode of the instrument must be started and stopped at the same time as the particulate emission test run in order to determine the instrument readings over the time period.

### Non-isokinetic sampling

Certain collectors do not have ducted emissions, in these situations it is only possible to carry out an indicative test by non-isokinetic sampling just inside the discharge grille. It is not possible to guarantee the accuracy of this test although it can serve to demonstrate that the filter is working correctly and to show compliance with the emission limits of 50 or 100mg/m<sup>3</sup>.