



1618

Report on Emissions to Atmosphere from the Spray Booths at the Nationwide Crash Repair Centre Coventry.

Report Reference: 07/042A
Report Issue Date: 18th May 2007
Client: Nationwide Crash Repair Center
Stonybridge Trading Estate
Rowley Drive
Coventry
CV3 4FG

Tests marked * with an asterisk are "not UKAS accredited" and are not included in the laboratory's accreditation schedule.

Opinions and interpretations expressed herein are outside the scope of UKAS accreditation.

If any results contained in this report were obtained from a sub-contracted laboratory then the identity of the testing laboratory will be clearly identified.

Report Author:

[REDACTED]
C.M. Greenaway
Team Leader Source Testing

Authorised by :

[REDACTED]
G. Carroll BSc (Hons.)
Head of Source Testing

EXECUTIVE SUMMARY

CPL Laboratories were requested by Mr. M. Rose to monitor emissions to atmosphere from the spray booth stacks at Nationwide Crash Repair Centre, Coventry.

The monitoring was carried out between the 28th February and the 1st March 2007 for the determination of total particulate matter.

1. INTRODUCTION

CPL Laboratories were requested by Mr. M. Rose to monitor emissions to atmosphere from the spray booth stacks at Nationwide Crash Repair Centre, Coventry. C.M. Greenaway and C. Hutton carried out the monitoring between 28th February and 1st March 2007 for the determination of total particulate matter.

2. SAMPLING PROCEDURE

Monitoring for total particulate matter was carried out in duplicate on each spray booth throughout the day, including preliminary measurements to determine the volumetric flow. Sampling duration was dependant on the size of car parts been sprayed at the time of sampling. Gas velocities and temperatures were measured across two mutually perpendicular axes at the sampling plane.

Sampling was carried out to BS3405 and BS6069, since the site were unable to change the sampling ports in time so that sampling to BS EN 13284 could be carried out.

2.1 Moisture

A measured volume of stack gas was withdrawn through a condensing coil to a pre-weighed gas cooler and silica gel by in-house method ST2. After sampling, the cooler and silica gel were re-weighed and the moisture content calculated.

2.2 Particulate Matter

The particulate testing was in accordance with the in-house procedure ST4, which is based upon BS3405:1983 and BS6069:1992. Four point sampling for particulate matter was carried out on the boiler stack to comply with the requirements specified in BS3405:1983 and BS6069:1992.

Gas velocities and temperatures were measured across two mutually perpendicular axes at the sampling plane to determine the relevant isokinetic flow rates and collect data required by BS3405:1983.

The probe was inserted into the gas flow and set to withdraw gas at the relevant isokinetic rate from each of the sampling positions. Gases were drawn through a sharp edged nozzle and probe to an internal filter assembly containing a pre-weighed glass fibre filter. The filtered gas was then drawn through a silica gel drying train, pump, dry gas meter and rotameter (for a visual indication of the sampling flow rate).

At the end of each test the filter assembly containing the filter was removed and stored. The probe, filter assembly and nozzle were then rinsed with water, the washings being collected and filtered through a separate pre-weighed filter. After drying and conditioning, the filter was re-weighed and the mass of the particulate matter collected derived.

3. **RESULTS**

The results of the monitoring and analysis are summarised in the Tables section.

Appendix A details the status of conditions covered by the procedural requirements of BS 3405:1983.

Appendix B details all relevant monitoring data.

Appendix C details calculations used.

4. **DISCUSSION OF RESULTS**

The level of uncertainty quoted for particulate matter results carried out to BS 3405 is c.25%. Details relating to non-compliance against the procedural requirements of BS3405 are listed in Appendix A. The procedural requirements were not fully satisfied, and as a consequence of this, the uncertainty associated with the results may be greater than 25%.

For future sampling campaigns to be carried out in accordance with BS EN 13284 the ports will require changing and alterations made to the sampling platforms e.t.c.

Tables

Summary of Emissions Monitoring Results

Table 1 Spray Booth 1 - 01/03/07

Emission Results	Test 1	Test 2	Mean	Emission Limit
Particulate Matter mg/m ³	1.8	2.0	1.9	10
Moisture %	1.3	1.4	1.35	--

Table 2 Spray Booth 2 - 28/02/07

Emission Results	Test 1	Test 2	Mean	Emission Limit
Particulate Matter mg/m ³	<0.7#	0.98	-	10
Moisture %	2.5	2.9	2.7	--

Table 3 Spray Booth 3 - 01/03/07

Emission Results	Test 1	Test 2	Mean	Emission Limit
Particulate Matter mg/m ³	1.9	<0.6#	-	10
Moisture %	1.8	1.6	1.7	--

Reference conditions 273K, 101.3 kPa.

* Tests marked with an asterisk are "not UKAS accredited" and are not included in the laboratory's accreditation schedule.

Test results found to be below the analytical "Limit of Detection".

Schematic Drawing of Sampling Location

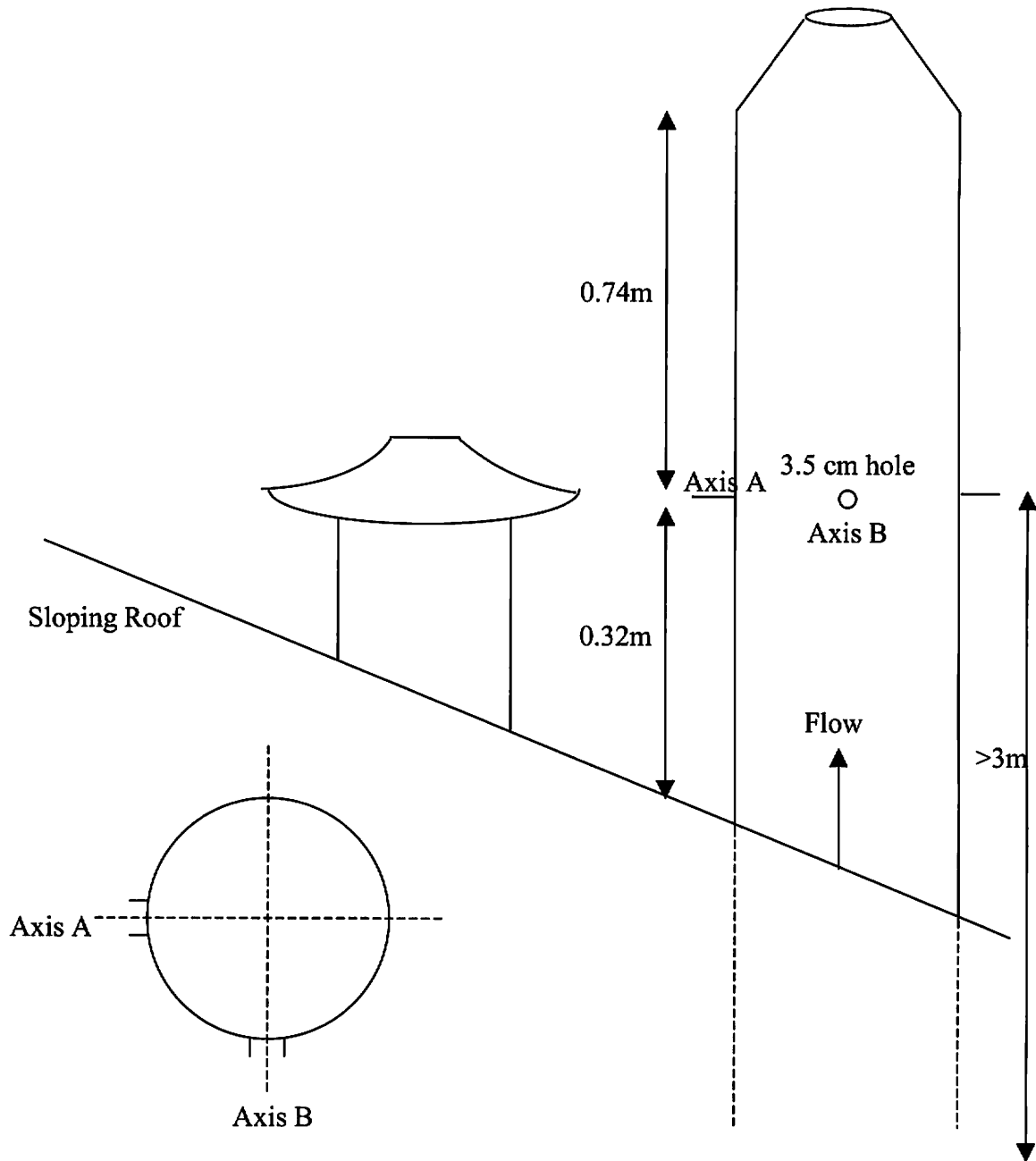

Appendix A

Appendix A

Status of Monitoring Conditions
re: Procedural Requirements of BS 3405

Booth 1

Did all conditions comply with procedural requirements in BS 3405?		YES
	<u>Status of Individual Requirements</u>	Satisfied ✓ Not satisfied X
a	No water droplets present	✓
b	Gas pitot:static pressure positive & > 5 Pa	✓
c	gas flow within $\pm 20^\circ$ of duct wall direction	✓
d	Suitable gas temperature profile i.e. absolute temperature variation from mean $< \pm 10\%$	✓
e	Suitable velocity profile i.e. highest:lowest velocities $< 3:1$: (pitot:static $< 9:1$)	✓
f	change in mean velocity during test $< \pm 5\%$ (change in mean pitot:static during test $< \pm 10\%$)	✓ ✓
g	Duct dimensions measured to $\pm 10\text{mm/m}$	✓
h	area of sampling head $< 10\%$ of duct area	✓
i	sampled at relevant positions (centres of equal area)	✓
j	appropriate number of points sampled (4 or 8 per plane)	✓
k	Sample duration at each point > 3 mins.	✓
l	constant nozzle area x duration at each point sampled [a x t]	✓
m	isokinetic sample rate maintained during test	✓
n	collected mass > 0.3% of filter/container mass	✓
o	ratio of individual mass emissions $< 1.5 : 1.0$	✓
p	<u>Geometric position of sample plane</u> > 1 duct diameter from outlet	✓
	> 1 duct diameter upstream of bend	✓
	> 2 duct diameter downstream of bend	✓
	> 3 duct diameter from partially closed damper	✓
	> 4 duct diameter from a fan	✓
	<i>If any condition in section "p" is not satisfied - then consider section "q"</i>	
q	BS 3405:Appendix A conditions (if applicable)	not applicable
	> 0.5 duct diameter upstream of bend or obstruction, or	
	> 0.67 duct diameter downstream of bend or obstruction, provided that :-	
	CSA of duct $> 2\text{m}^2$ & velocity $> 8\text{m/s}$ and a minimum of 3 tests is carried out	

Appendix A

Booth 2

Did all conditions comply with procedural requirements in BS 3405?		No
	<u>Status of Individual Requirements</u>	Satisfied ✓ Not satisfied X
a	No water droplets present	✓
b	Gas pitot:static pressure positive & > 5 Pa	X
c	gas flow within $\pm 20^\circ$ of duct wall direction	✓
d	Suitable gas temperature profile i.e. absolute temperature variation from mean $< \pm 10\%$	✓
e	Suitable velocity profile i.e. highest:lowest velocities $< 3:1$: (pitot:static $< 9:1$)	X
f	change in mean velocity during test $< \pm 5\%$ (change in mean pitot:static during test $< \pm 10\%$)	✓ ✓
g	Duct dimensions measured to $\pm 10\text{mm/m}$	✓
h	area of sampling head $< 10\%$ of duct area	✓
i	sampled at relevant positions (centres of equal area)	✓
j	appropriate number of points sampled (4 or 8 per plane)	✓
k	Sample duration at each point > 3 mins.	✓
l	constant nozzle area x duration at each point sampled [a x t]	✓
m	isokinetic sample rate maintained during test	✓
n	collected mass $> 0.3\%$ of filter/container mass	X
o	ratio of individual mass emissions $< 1.5 : 1.0$	X
p	<u>Geometric position of sample plane</u> > 1 duct diameter from outlet	✓
	> 1 duct diameter upstream of bend	✓
	> 2 duct diameter downstream of bend	✓
	> 3 duct diameter from partially closed damper	✓
	> 4 duct diameter from a fan	✓
	<i>If any condition in section "p" is not satisfied - then consider section "q"</i>	
q	BS 3405:Appendix A conditions (if applicable)	not applicable
	> 0.5 duct diameter upstream of bend or obstruction, or	
	> 0.67 duct diameter downstream of bend or obstruction, provided that :-	
	CSA of duct $> 2\text{m}^2$ & velocity $> 8\text{m/s}$ and a minimum of 3 tests is carried out	

Appendix A

Booth 3

Did all conditions comply with procedural requirements in BS 3405?		No
<u>Status of Individual Requirements</u>		Satisfied ✓ Not satisfied X
a	No water droplets present	✓
b	Gas pitot:static pressure positive & > 5 Pa	X
c	gas flow within $\pm 20^\circ$ of duct wall direction	✓
d	Suitable gas temperature profile i.e. absolute temperature variation from mean $< \pm 10\%$	✓
e	Suitable velocity profile i.e. highest:lowest velocities $< 3:1$: (pitot:static $< 9:1$)	X
f	change in mean velocity during test $< \pm 5\%$ (change in mean pitot:static during test $< \pm 10\%$)	✓ ✓
g	Duct dimensions measured to $\pm 10\text{mm/m}$	✓
h	area of sampling head $< 10\%$ of duct area	✓
i	sampled at relevant positions (centres of equal area)	✓
j	appropriate number of points sampled (4 or 8 per plane)	✓
k	Sample duration at each point > 3 mins.	✓
l	constant nozzle area x duration at each point sampled [a x t]	✓
m	isokinetic sample rate maintained during test	✓
n	collected mass $> 0.3\%$ of filter/container mass	X
o	ratio of individual mass emissions $< 1.5 : 1.0$	X
p	<u>Geometric position of sample plane</u> > 1 duct diameter from outlet	✓
	> 1 duct diameter upstream of bend	✓
	> 2 duct diameter downstream of bend	✓
	> 3 duct diameter from partially closed damper	✓
	> 4 duct diameter from a fan	✓
<i>If any condition in section "p" is not satisfied - then consider section "q"</i>		
q	BS 3405:Appendix A conditions (if applicable)	not applicable
	> 0.5 duct diameter upstream of bend or obstruction, or	
	> 0.67 duct diameter downstream of bend or obstruction, provided that :-	
	CSA of duct $> 2\text{m}^2$ & velocity $> 8\text{m/s}$ and a minimum of 3 tests is carried out	

Appendix B

Moisture Test		1	2	3
Final mass of moisture train	g	420.8	423.8	
Initial mass of moisture train	g	418.0	420.8	
Mass of moisture collected	g	2.8	3.0	0.0
Final Meter reading	m ³	211.3966	211.6784	
Initial meter reading	m ³	211.1240	211.3989	
Meter Calibration Factor		1.018	1.018	
Volume sampled at meter conditions	litres	277.5	284.5	0.0
Mean Meter Temperature	K	286	288	
Mean Meter Pressure	kPa	98.6	98.6	
Volume Sampled at reference conditions	litres	257.8	262.2	
Water content Vol/Vol	%	1.3	1.4	
Mean Water Content	%	1.4		

Duct diameter is 0.755 m					
	Axis A (LHS)		Axis B (RHS)		
	Position	Pitot, Pa	Temp, K	Pitot, Pa	Temp, K
	1	19	299	45	300
	2	38	299	49	300
	3	22	299	43	300
	4	31	299	50	300
	5	36	299	44	300
	6	27	299	33	300
	7	47	299	49	300
	8	48	299	48	300
	9	50	299	48	299
	10	45	299	44	299
	Mean Pitot, Pa	34		45	
	Mean Temperature, K	Ta	299	Tb	300
	Mean flow	8.3 m/s			
Static Duct Pressure	-0.1 kPa				
Barometric Pressure	98.6 kPa				
Relative Duct Pressure	98.5 kPa				
Mean T(duct) = (Ta+Tb...Tn) / (no. of axes[n])	299 K				
A highest Pitot	50 Pa				
B Lowest Pitot	19 Pa				
Ratio A/B (Highest permitted ratio = 9/1)	2.6 / 1 Within range				

Nationwide Crash Repair Center Spray Booth 1

Appendix B

Nationwide Crash Repair Centre SprayBooth 1

Measurements relating to sampling											
Position	Duct Temperature, T(duct)						Duct Pitot-static Pressure, h				
	Before Test 1	After Test 1	Before Test 2	After Test 2	Before Test 3	After Test 3	Before Test 1	After Test 1	Before Test 2	After Test 2	Before Test 3
1	299	299	299	299			38	39	39	40	
2	299	299	299	299			50	51	51	50	
3	300	299	299	299			40	40	40	42	
4	299	299	299	299			48	47	47	45	
Mean, K	299	299	299	299			Total	176	177	177	177
Local Duct Velocity Measurements, ms ⁻¹											
Position	Before	After	Before	After	Before	After	Barometric Pressure, kPa				
	Test 1	Test 2	Test 1	Test 2	Test 3	Test 3	Test 1	Test 2			
1	8.0	8.1	8.1	8.2			98.6	98.6			
2	9.2	9.3	9.3	9.2			Relative Duct Pressure (Static), kPa	-0.13	-0.13		
3	8.2	8.2	8.2	8.4			Meter Pressure, kPa	98.6	98.6		
4	9.0	8.9	8.9	8.7			Meter Temperature, K	286	288.3		
Mean	8.6	8.6	8.6	8.6							
Permitted range for sum duct pitot-static readings (after test) +/- 10%											
			from	to	Within						
			-10%	+10%	Range						
range, Pa = 0.9 to 1.1 x total h (before test)			Test 1	158	194	✓					
			Test 2	159	195	✓					
			Test 3								
Permitted range for velocity readings (after test) +/- 5%											
			from	to	Within						
			-5%	+5%	Range						
range, Velocity = 0.95 to 1.05 x mean duct sampling velocity			Test 1	8.2	9.0	✓					
			Test 2	8.2	9.0	✓					
			Test 3								

Appendix B

Sampling Data Test 1		
Throughput		
Comments		
Time Sampling Finished		12:44
Time Sampling Started		12:22
Sampling Time Period, mins	t	20
Nozzle Area Size, m ²	a	0.000028
Final Meter Reading, m ³		211.3966
Initial Meter Reading, m ³		211.1240
Meter Calibration Factor		1.018
Mean Meter Pressure, kPa		98.6
Mean Meter Temperature, K		286.0
Actual Volume sampled		
at meter temperature and pressure, litres		277.5
Mean Ideal sampling rate, l/min	Vs	14.1
Total Ideal Isokinetic Volume, litres	t x Vs	281.1
Deviation from isokinetic, %		-1.3

Filter Number	07-020
Filter + particulates, g	0.0266
Filter, g	0.0262
Mass collected, g	0.00046
Washing Bottle Number	0
Washing Filter + particulates, g	0.0000
Washing Filter, g	0.0000
Mass collected, g	0.0000
Total Mass collected, g	0.00046

Calculation For Test 1			
		Average during test	Reference Conditions
Mean Duct Temperature	K	299	273
Mean Relative Duct Static Pressure	kPa	98.5	101.3
Mean Duct Oxygen Content	% v/v	0.0	0.0
Without correction to dry basis			
Mean Square root of Duct Temperature	\sqrt{T}	17.30	
Mean Square root of Relative Duct Pressure	\sqrt{h}	6.63	
Area of duct, m ²	A	0.448	
number of sampling positions	n	4	
Nozzle area at first sampling position, m ²	a	0.000028	
Duration of sampling at first position, mins	t	5	
Total mass of particulates collected, g	w	0.0005	
	Formula Number		
(V), Mean Local Velocity at duct temperature	(2)	8.6 m/s	
(Q _(duct)), Flow in the duct, at duct conditions	(3)	3.9 m ³ /s	
(Q _o), Flow in the duct, at reference conditions	(4)	3.4 m ³ /s	
(M), Mass Flow at duct conditions	(5)	0.022 kg/hr	
(C), Concentration of particulate matter at reference conditions	(6)	1.8 mg/m ³	

Nationwide Crash Repair Centre SprayBooth 1

Appendix B

Sampling Data Test 2		
Throughput		
Comments		
Time Sampling Finished		13:12
Time Sampling Started		12:51
Sampling Time Period, mins	t	20
Nozzle Area Size, m ²	a	0.000028
Final Meter Reading, m ³		211.6784
Initial Meter Reading, m ³		211.3989
Meter Calibration Factor		1.018
Mean Meter Pressure, kPa		98.6
Mean Meter Temperature, K		288.3
Actual Volume sampled at meter temperature and pressure, litres		284.5
Mean Ideal sampling rate, l/min	Vs	14.2
Total Ideal Isokinetic Volume, litres	t x Vs	283.9
Deviation from isokinetic, %		0.2

Filter Number	07-022
Filter + particulates, g	0.0266
Filter, g	0.0261
Mass collected, g	0.00053
Washing Bottle Number	0
Washing Filter + particulates, g	0.0000
Washing Filter, g	0.0000
Mass collected, g	0.0000
Total Mass collected, g	0.00053

Calculation For Test 2			
		Average during test	Reference Conditions
Mean Duct Temperature	K	299	273
Mean Relative Duct Static Pressure	kPa	98.5	101.3
Mean Duct Oxygen Content	% v/v	0.0	0.0
Without correction to dry basis			
Mean Square root of Duct Temperature	\sqrt{T}	17.29	
Mean Square root of Relative Duct Pressure	\sqrt{h}	6.64	
Area of duct, m ²	A	0.448	
number of sampling positions	n	4	
Nozzle area at first sampling position, m ²	a	0.000028	
Duration of sampling at first position, mins	t	5	
Total mass of particulates collected, g	w	0.0005	
	Formula Number		
(V), Mean Local Velocity at duct temperature	(2)	8.7 m/s	
(Q _(duct)), Flow in the duct, at duct conditions	(3)	3.9 m ³ /s	
(Q ₀), Flow in the duct, at reference conditions	(4)	3.4 m ³ /s	
(M), Mass Flow at duct conditions	(5)	0.025 kg/hr	
(C), Concentration of particulate matter at reference conditions	(6)	2.0 mg/m ³	

Nationwide Crash Repair Centre SprayBooth 1

Appendix B

Nationwide repair centre Spray Booth 2

Measurements relating to sampling											
Position	Duct Temperature, T(duct)						Duct Pitot-static Pressure, h				
	Before Test 1	After Test 1	Before Test 2	After Test 2	Before Test 3	After Test 3	Before Test 1	After Test 1	Before Test 2	After Test 2	Before Test 3
1	300	299	299	300			20	20	20	21	
2	299	299	299	299			3	3	3	4	
3	299	299	299	299			23	9	9	9	
4	300	299	299	300			10	17	17	18	
Mean, K	299	299	299	299			Total	56	49	49	52

Position	Local Duct Velocity Measurements, ms ⁻¹						Barometric Pressure, kPa	
	Before Test 1	After Test 1	Before Test 2	After Test 2	Before Test 3	After Test 3	Test 1	Test 2
1	5.8	5.8	5.8	6.0			98.1	98.1
2	2.3	2.3	2.3	2.6			-0.008	-0.076
3	6.3	3.9	3.9	3.9			98.1	98.1
4	4.1	5.4	5.4	5.5			287	284.55
Mean	4.6	4.4	4.4	4.5				

Permitted range for sum duct pitot-static readings (after test) +/- 10%				
range, Pa = 0.9 to 1.1 x total h (before test)	Test 1	Test 2	Test 3	Within Range
				from -10%
	50	62		X
	44	54		✓

Permitted range for velocity readings (after test) +/- 5%				
range, Velocity = 0.95 to 1.05 x mean duct sampling velocity	Test 1	Test 2	Test 3	Within Range
				from -5%
	4.4	4.8		✓
	4.2	4.6		✓

Appendix B

Moisture Test		1	2	3
Final mass of moisture train	g	243.9	247.0	
Initial mass of moisture train	g	241.1	243.9	
Mass of moisture collected	g	2.8	3.1	0.0
Final Meter reading	m ³	210.6402	210.7834	
Initial meter reading	m ³	210.4967	210.6470	
Meter Calibration Factor		1.018	1.018	
Volume sampled at meter conditions	litres	146.1	138.9	0.0
Mean Meter Temperature	K	287	285	
Mean Meter Pressure	kPa	98.3	98.1	
Volume Sampled at reference conditions	litres	134.8	129.0	
Water content Vol/Vol	%	2.5	2.9	
Mean Water Content	%	2.7		

Duct diameter is 0.755 m					
	Axis A (LHS)			Axis B (RHS)	
Position	Pitot, Pa	Temp, K	Pitot, Pa	Temp, K	
1	10	298	8	298	
2	20	299	23	299	
3	18	299	32	299	
4	17	299	28	299	
5	33	299	32	299	
6	35	299	29	299	
7	32	299	33	299	
8	2	299	20	299	
9	3	299	10	299	
10	4	299	8	299	
Mean Pitot, Pa	21		26		
Mean Temperature, K	Ta	299	Tb	299	
Mean flow	5.5 m/s				
Static Duct Pressure	-0.1 kPa				
Barometric Pressure	98.4 kPa				
Relative Duct Pressure	98.3 kPa				
Mean T(duct) = (Ta+Tb...Tn)/ (no. of axes[n])	299 K				
A highest Pitot	35 Pa				
B Lowest Pitot	2 Pa				
Ratio A/B (Highest permitted ratio = 9/1)	17.5 /1 Not permitted				

Nationwide Crash repair centre Spray Booth 2

Appendix B

Sampling Data Test 1		
Throughput		
Comments		
Time Sampling Finished		12:10
Time Sampling Started		11:50
Sampling Time Period, mins	t	20
Nozzle Area Size, m ²	a	0.000028
Final Meter Reading, m ³		210.6402
Initial Meter Reading, m ³		210.4967
Meter Calibration Factor		1.018
Mean Meter Pressure, kPa		98.1
Mean Meter Temperature, K		287.0
Actual Volume sampled at meter temperature and pressure, litres		146.1
Mean Ideal sampling rate, l/min	Vs	7.2
Total Ideal Isokinetic Volume, litres	t x Vs	145.0
Deviation from isokinetic, %		0.8

Filter Number	07-015
Filter + particulates, g	0.0257
Filter, g	0.0258
Mass collected, g	-7E-05
Washing Bottle Number	0
Washing Filter + particulates, g	0.0000
Washing Filter, g	0.0000
Mass collected, g	0.0000
Total Mass collected, g	-7E-05

Calculation For Test 1			
		Average during test	Reference Conditions
Mean Duct Temperature	K	299	273
Mean Relative Duct Static Pressure	kPa	98.1	101.3
Mean Duct Oxygen Content	% v/v	0.0	0.0
Without correction to dry basis			
Mean Square root of Duct Temperature	\sqrt{T}	17.30	
Mean Square root of Relative Duct Pressure	\sqrt{h}	3.44	
Area of duct, m ²	A	0.448	
number of sampling positions	n	4	
Nozzle area at first sampling position, m ²	a	0.000028	
Duration of sampling at first position, mins	t	5	
Total mass of particulates collected, g	w	-0.0001	
	Formula Number		
(V), Mean Local Velocity at duct temperature	(2)	4.5 m/s	
(Q _(duct)), Flow in the duct, at duct conditions	(3)	2.0 m ³ /s	
(Q _o), Flow in the duct, at reference conditions	(4)	1.8 m ³ /s	
(M), Mass Flow at duct conditions	(5)	-0.003 kg/hr	
(C), Concentration of particulate matter at reference conditions	(6)	-0.5 mg/m ³	

Nationwide repair centre Spray Booth 2

Appendix B

Sampling Data Test 2		
Throughput		
Comments		
Time Sampling Finished		15:08
Time Sampling Started		14:47
Sampling Time Period, mins	t	20
Nozzle Area Size, m ²	a	0.000028
Final Meter Reading, m ³		210.7834
Initial Meter Reading, m ³		210.6470
Meter Calibration Factor		1.018
Mean Meter Pressure, kPa		98.1
Mean Meter Temperature, K		284.6
Actual Volume sampled at meter temperature and pressure, litres		138.9
Mean Ideal sampling rate, l/min	Vs	7.1
Total Ideal Isokinetic Volume, litres	t x Vs	141.9
Deviation from isokinetic, %		-2.2

Filter Number	07-017
Filter + particulates, g	0.0258
Filter, g	0.0257
Mass collected, g	0.00013
Washing Bottle Number	0
Washing Filter + particulates, g	0.0000
Washing Filter, g	0.0000
Mass collected, g	0.0000
Total Mass collected, g	0.00013

Calculation For Test 2			
		Average during test	Reference Conditions
Mean Duct Temperature	K	299	273
Mean Relative Duct Static Pressure	kPa	98.0	101.3
Mean Duct Oxygen Content	% v/v	0.0	0.0
Without correction to dry basis			
Mean Square root of Duct Temperature	\sqrt{T}	17.30	
Mean Square root of Relative Duct Pressure	\sqrt{h}	3.39	
Area of duct, m ²	A	0.448	
number of sampling positions	n	4	
Nozzle area at first sampling position, m ²	a	0.000028	
Duration of sampling at first position, mins	t	5	
Total mass of particulates collected, g	w	0.0001	
	Formula Number		
(V), Mean Local Velocity at duct temperature	(2)	4.4 m/s	
(Q _(duct)), Flow in the duct, at duct conditions	(3)	2.0 m ³ /s	
(Q _o), Flow in the duct, at reference conditions	(4)	1.7 m ³ /s	
(M), Mass Flow at duct conditions	(5)	0.006 kg/hr	
(C), Concentration of particulate matter at reference conditions	(6)	0.98 mg/m ³	

Nationwide Crash repair centre Spray Booth 2

Appendix B

Moisture Test		1	2	3
Final mass of moisture train	g	249.2	251.3	
Initial mass of moisture train	g	247.0	249.2	
Mass of moisture collected	g	2.2	2.1	0.0
Final Meter reading	m ³	210.9492	211.1229	
Initial meter reading	m ³	210.7818	210.9498	
Meter Calibration Factor		1.018	1.018	
Volume sampled at meter conditions	litres	170.4	176.2	0.0
Mean Meter Temperature	K	284	286	
Mean Meter Pressure	kPa	98.4	98.4	
Volume Sampled at reference conditions	litres	158.9	163.4	
Water content Vol/Vol	%	1.7	1.6	
Mean Water Content	%	1.7		

Duct diameter is 0.755 m					
	Axis A (LHS)			Axis B (RHS)	
	Position	Pitot, Pa	Temp, K	Pitot, Pa	Temp, K
	1	7	302	54	303
	2	10	302	25	304
	3	17	303	20	304
	4	10	303	8	303
	5	23	303	8	303
	6	17	303	6	303
	7	17	303	9	303
	8	28	302	13	303
	9	24	302	10	303
	10	14	300	4	303
	Mean Pitot, Pa	16		18	
	Mean Temperature, K	Ta	302	Tb	303
	Mean flow	5.0 m/s			
	Static Duct Pressure	-0.2 kPa			
	Barometric Pressure	98.4 kPa			
	Relative Duct Pressure	98.2 kPa			
	Mean T(duct) = (Ta+Tb...Tn)/ (no. of axes[n])	303 K			
	A highest Pitot	54 Pa			
	B Lowest Pitot	4 Pa			
	Ratio A/B (Highest permitted ratio = 9/1)	13.5 /1 Not permitted			

Nationwide Crash Repair centre Spray Booth 3

Appendix B

Nationwide Crash Repair centre Spray Booth 3

Measurements relating to sampling											
Position	Duct Temperature, T(duct)						Duct Pitot-static Pressure, h				
	Before Test 1	After Test 1	Before Test 2	After Test 2	Before Test 3	After Test 3	Before Test 1	After Test 1	Before Test 2	After Test 2	Before Test 3
1	302	303	303	304			10	12	12	12	
2	302	303	303	304			24	16	16	25	
3	304	304	304	304			25	28	28	27	
4	303	304	304	304			10	12	12	11	
Mean, K	303	303	303	304			Total	69	68	68	75
Local Duct Velocity Measurements, ms ⁻¹											
Position	Test 1		Test 2		Test 3		Test 1		Test 2		
	Before	After	Before	After	Before	After	Barometric Pressure, kPa	98.35	98.35	98.35	
1	4.1	4.5	4.5	4.5			Relative Duct Pressure (Static), kPa	-0.2	-0.2	-0.2	
2	6.4	5.2	5.2	6.6			Meter Pressure, kPa	98.35	98.35	98.35	
3	6.6	6.9	6.9	6.8			Meter Temperature, K	284.2	285.85	285.85	
4	4.1	4.5	4.5	4.4							
Mean	5.3	5.3	5.3	5.6							
Permitted range for sum duct pitot-static readings (after test) +/- 10%											
			from -10%	to +10%	Within Range						
range, Pa = 0.9 to 1.1 x total h (before test)			Test 1	62	76	✓					
			Test 2	61	75	✓					
			Test 3								
Permitted range for velocity readings (after test) +/- 5%											
			from -5%	to +5%	Within Range						
range, Velocity = 0.95 to 1.05 x mean duct sampling velocity			Test 1	5.0	5.6	✓					
			Test 2	5.0	5.6	✓					
			Test 3								

Appendix B

Sampling Data Test 1		
Throughput		
Comments		
Time Sampling Finished		09:51
Time Sampling Started		09:29
Sampling Time Period, mins	t	20
Nozzle Area Size, m ²	a	0.000028
Final Meter Reading, m ³		210.9492
Initial Meter Reading, m ³		210.7818
Meter Calibration Factor		1.018
Mean Meter Pressure, kPa		98.4
Mean Meter Temperature, K		284.2
Actual Volume sampled at meter temperature and pressure, litres		170.4
Mean Ideal sampling rate, l/min	V _s	8.5
Total Ideal Isokinetic Volume, litres	t x V _s	169.5
Deviation from isokinetic, %		0.5

Filter Number	07-024
Filter + particulates, g	0.0263
Filter, g	0.0260
Mass collected, g	0.0003
Washing Bottle Number	0
Washing Filter + particulates, g	0.0000
Washing Filter, g	0.0000
Mass collected, g	0.0000
Total Mass collected, g	0.0003

Calculation For Test 1			
		Average during test	Reference Conditions
Mean Duct Temperature	K	303	273
Mean Relative Duct Static Pressure	kPa	98.2	101.3
Mean Duct Oxygen Content	% v/v	0.0	0.0
Without correction to dry basis			
Mean Square root of Duct Temperature	\sqrt{T}	17.41	
Mean Square root of Relative Duct Pressure	\sqrt{h}	4.06	
Area of duct, m ²	A	0.448	
number of sampling positions	n	4	
Nozzle area at first sampling position, m ²	a	0.000028	
Duration of sampling at first position, mins	t	5	
Total mass of particulates collected, g	w	0.0003	
	Formula Number		
(V), Mean Local Velocity at duct temperature	(2)	5.3 m/s	
(Q _(duct)), Flow in the duct, at duct conditions	(3)	2.4 m ³ /s	
(Q _o), Flow in the duct, at reference conditions	(4)	2.1 m ³ /s	
(M), Mass Flow at duct conditions	(5)	0.014 kg/hr	
(C), Concentration of particulate matter at reference conditions	(6)	1.9 mg/m ³	

Nationwide Crash Repair centre Spray Booth 3

Appendix B

Sampling Data Test 2		
Throughput		
Comments		
Time Sampling Finished		10:46
Time Sampling Started		10:24
Sampling Time Period, mins	t	20
Nozzle Area Size, m ²	a	0.000028
Final Meter Reading, m ³		211.1229
Initial Meter Reading, m ³		210.9498
Meter Calibration Factor		1.018
Mean Meter Pressure, kPa		98.4
Mean Meter Temperature, K		285.9
Actual Volume sampled		
at meter temperature and pressure, litres		176.2
Mean Ideal sampling rate, l/min	Vs	8.7
Total Ideal Isokinetic Volume, litres	t x Vs	174.3
Deviation from isokinetic, %		1.1

Filter Number	07-023
Filter + particulates, g	0.0261
Filter, g	0.0261
Mass collected, g	0
Washing Bottle Number	0
Washing Filter + particulates, g	0.0000
Washing Filter, g	0.0000
Mass collected, g	0.0000
Total Mass collected, g	0

Calculation For Test 2			
		Average during test	Reference Conditions
Mean Duct Temperature	K	304	273
Mean Relative Duct Static Pressure	kPa	98.2	101.3
Mean Duct Oxygen Content	% v/v	0.0	0.0
Without correction to dry basis			
Mean Square root of Duct Temperature	\sqrt{T}	17.42	
Mean Square root of Relative Duct Pressure	\sqrt{h}	4.15	
Area of duct, m ²	A	0.448	
number of sampling positions	n	4	
Nozzle area at first sampling position, m ²	a	0.000028	
Duration of sampling at first position, mins	t	5	
Total mass of particulates collected, g	w	0.0000	
	Formula Number		
(V), Mean Local Velocity at duct temperature	(2)	5.4 m/s	
(Q _{duct}), Flow in the duct, at duct conditions	(3)	2.4 m ³ /s	
(Q _o), Flow in the duct, at reference conditions	(4)	2.1 m ³ /s	
(M), Mass Flow at duct conditions	(5)	0.000 kg/hr	
(C), Concentration of particulate matter at reference conditions	(6)	0.0 mg/m ³	

Nationwide Crash Repair centre Spray Booth 3

Appendix C

Calculations used in the determination of on-site parameters

Formula 1 - Determination of Moisture Content

$$V_o = V_m \cdot (273 \div T_m) \cdot (P_b \div 101.3)$$

$$\% \text{H}_2\text{O} = 100 \cdot (M_w \div 18) \div [(V_o \div 22.412) + (M_w \div 18)]$$

Where :

- $\% \text{H}_2\text{O}$ - Moisture content of the gas sampled, %
- M_w - Mass of water collected during the test, g
- V_o - Volume sampled at reference conditions, litres
- V_m - Volume sampled at meter conditions, litres
- T_m - Mean meter temperature during the test, K
- P_b - Mean meter conditions during test, kPa

Formula 2 - Determination of mean velocity

$$V = 0.0753 \cdot \sqrt{T} \cdot \sqrt{h}$$

Where

- V - Mean velocity during test, m/s
- \sqrt{T} - Mean square root of temperatures before and after test, K
- \sqrt{h} - Mean square root of pitot-static readings before and after test, Pa

Formula 3 - Volume flow rate of duct gases, at duct temperatures

$$Q_{(\text{duct})} = V \cdot A$$

Where

- $Q_{(\text{duct})}$ - Volume flow rate of duct gases, m^3/s
- V - Mean velocity, m/s
- A - Area of duct (at the sampling plane), m^2

Appendix C

Formula 4 - Volume flow rate of duct gases, specified reference conditions

$$Q_0 = Q_{(duct)} \cdot (T_{ref} \div T_{duct}) \cdot (P_{duct} \div P_{ref}) \cdot [(100 - \%H_2O) \div 100] \cdot [(20.9 - O_{2duct}) \div (20.9 - O_{2rel})]$$

Where

- Q_0 - Volume flow rate at reference conditions, and relative O_2 and moisture correction, m^3/s
 T_{ref} - reference Temperature, K
 T_{duct} - Mean temperature across the duct, K
 P_{duct} - Relative static pressure in the duct, kPa
 P_{ref} - Reference pressure, kPa
 $\%H_2O$ - Water content, %
 O_{2duct} - Oxygen content as measured during the test, %v/v
 O_{2rel} - Relative Oxygen content for the process, %v/v

Formula 5 - Mass emission rate

$$M = (0.06 \cdot w \cdot A) \div (n \cdot a \cdot t)$$

Where

- M - Mass Emission rate, kg/hr
 w - Mass of particulates collected during the test, g
 A - Area of duct at the sampling position, m^2
 n - number of sampling positions
 a - Area of the nozzle used for sampling, m^2
 t - time sampling at the first sampling position, mins

Formula 6 - Particulate matter concentration

$$C = 0.277 \cdot (M \div Q_0)$$

Where

- C - Particulate matter concentration, g/m^3
 M - Mass emission for the test, kg/hr
 Q_0 - Volume flow rate at reference conditions specified, m^3/s

END OF REPORT